



# Қытай Банкінің ғимаратын күшейту

АТЫ-ЖӨНІ: .....

СЫНЫБЫ: .....

КҮНІ: .....

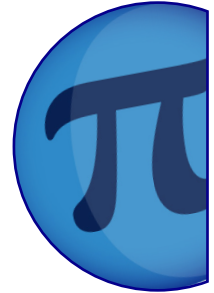

## Негізгі деңгей

1) Төмендегі үшбұрыштардың қайсысы: тең қабырғалы, тең бүйірлі, әр түрлі қабырғалы немесе тік бұрышты.

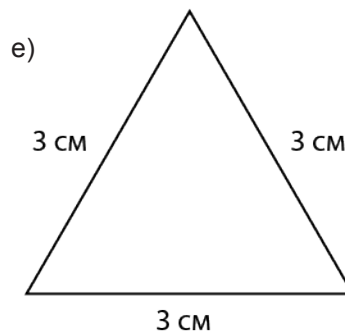
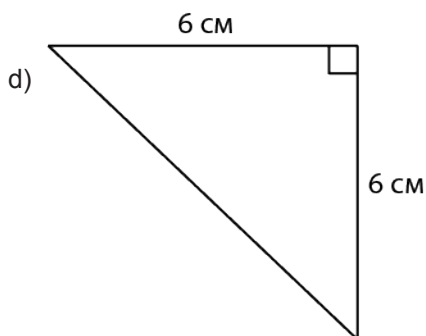
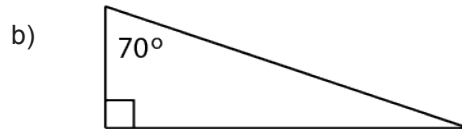
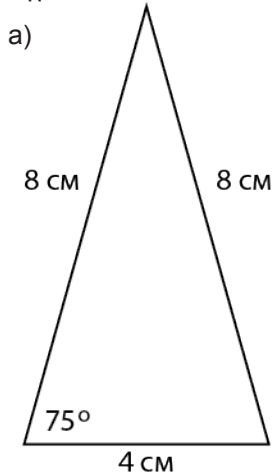

2) Жоғарыда берілген үшбұрыштардың белгісіз бұрыштарының мәнін есептеп шығарыңыз.



# Қытай Банкінің ғимаратын күшейту

АТЫ-ЖӨНІ: .....

СЫНЫБЫ: .....

КҮНІ: .....



## Орташа деңгей

1) Төмендегі үшбұрыштардың белгісіз бұрыштарының мәнін есептеп шығарыңыз.

a)

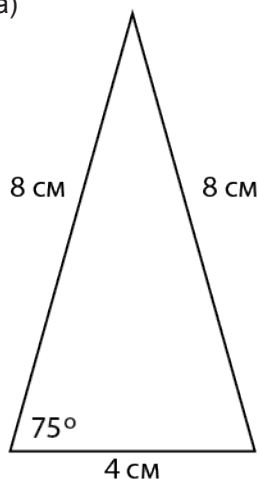

b)



c)

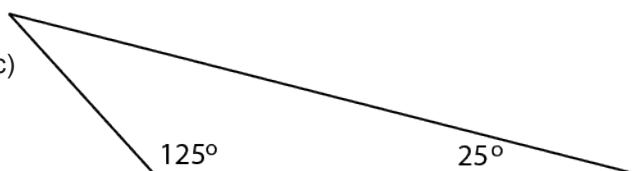

d)

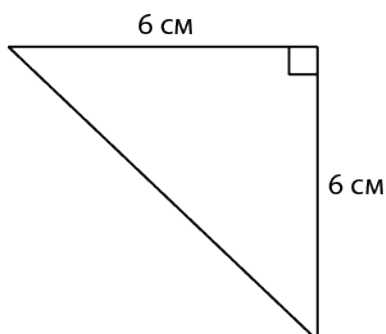

e)

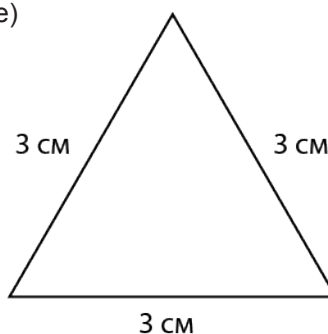

2) Жоғарыдағы әр үшбұрыштың барлық симметрия осьтерінің түзулерін салыңыз.



# Қытай Банкінің ғимаратын күшейту

АТЫ-ЖӨНІ: .....

СЫНЫБЫ: .....

КҮНІ: .....

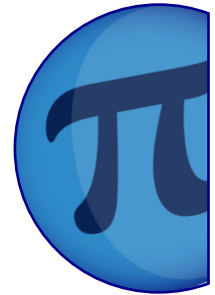

## Тереңдетілген деңгей

1) Төмендегі үшбұрыштардың белгісіз бұрыштарының мәнін есептеп шығарыңыз.

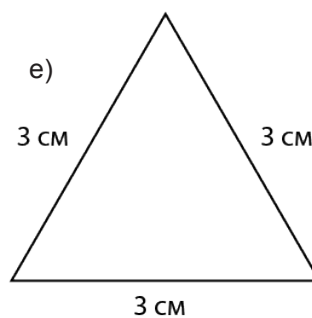
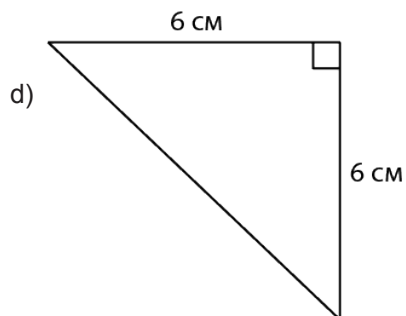
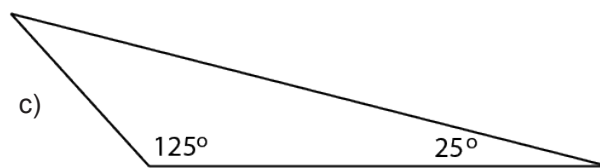
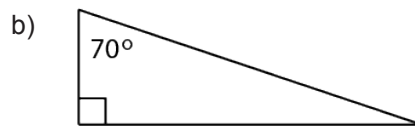
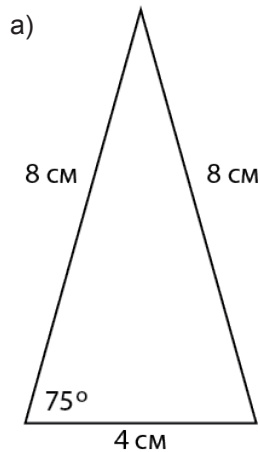

2) Төмендегі дұрыс көпбұрыштардың әрқайсысының ішкі бұрыштарының қосындысын есептеңіз:

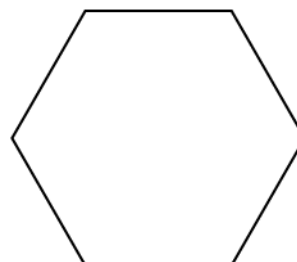
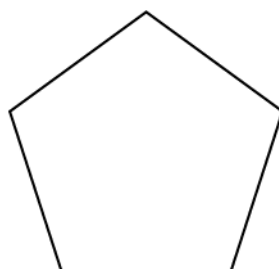
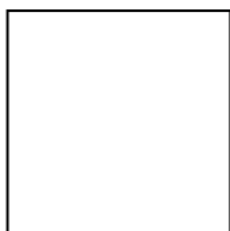



# Қытай Банкінің ғимаратын күшейту

## Жауаптар

### Негізгі деңгей

1) және 2)

a)

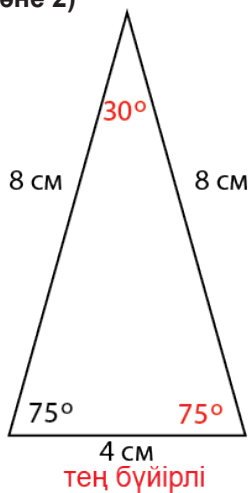

b)



c)



d)

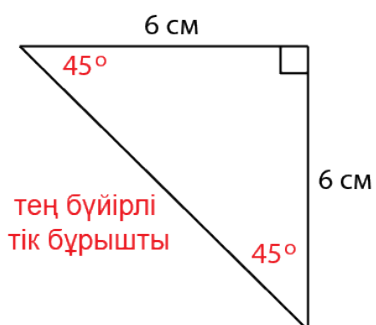

e)

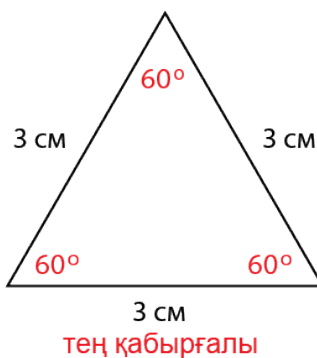



# Қытай Банкінің ғимаратын күшейту

Жауаптар

Орташа деңгей

1) және 2)

a)

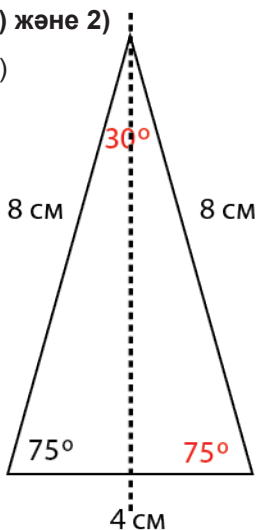

b)

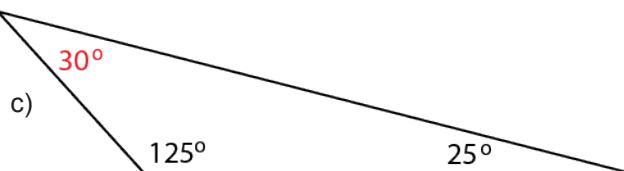

d)

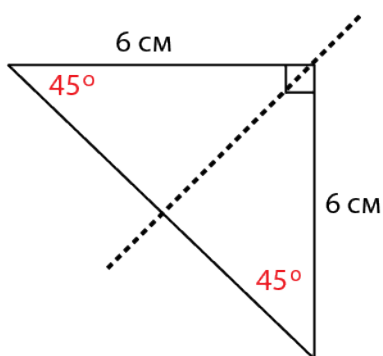

e)

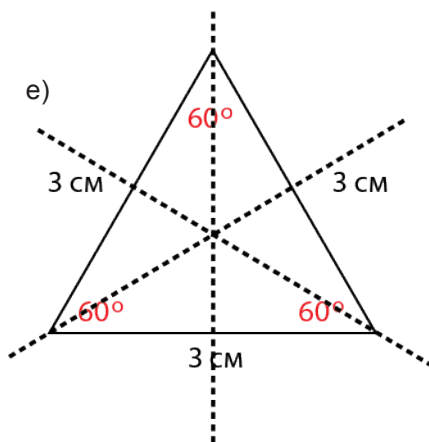



# Қытай Банкінің ғимаратын күшейту

## Жауаптар

### Тереңдетілген деңгей

1)

a)

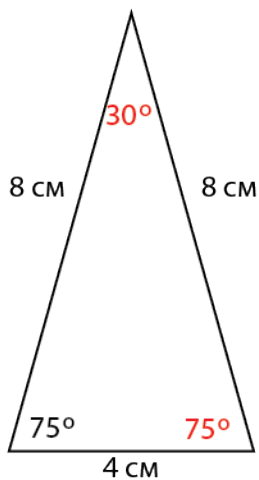

b)

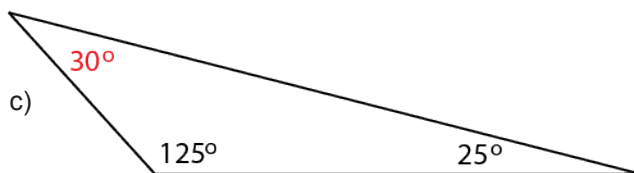

c)

d)

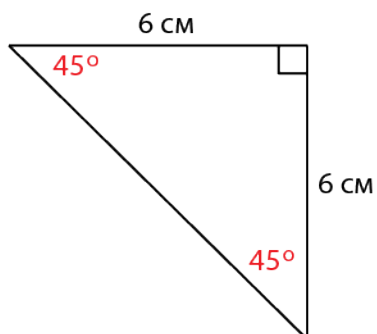

e)

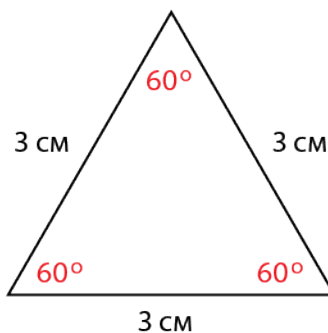

2) a)  $360^\circ$

b)  $540^\circ$

c)  $720^\circ$